

**SEOMAR**<sup>®</sup>

# 110-CP-6 SE

Flat Knitting Machine

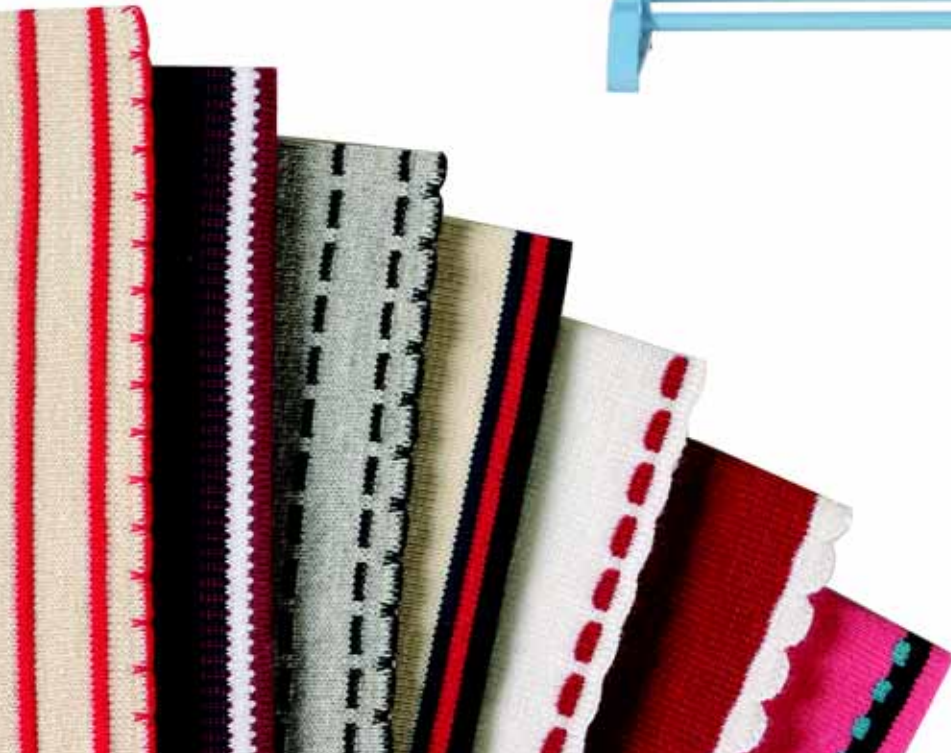
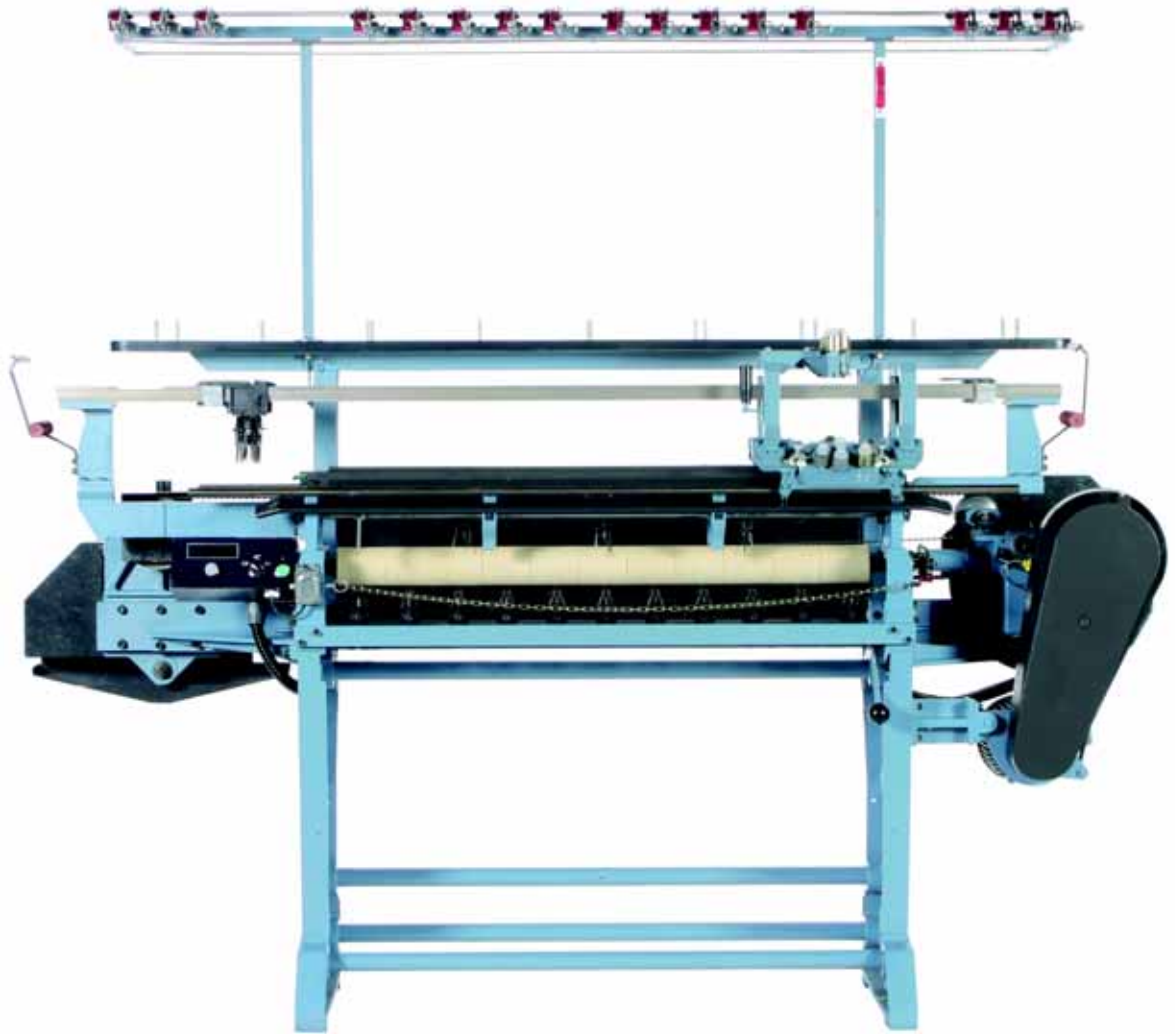

**VANGUARD  
SUPREME**

# 110-CP-6 SE

The Scomar 110-CP-6 SE is the leader in trim machines. The SE model is remanufactured according to Vanguard Supreme's new machine standards and updated with the latest computer control technology.

## Technical Characteristics

**NEEDLE BED:**

110 cm wide

**GAUGES:**

3, 5, 7, 8, 10, 12, 14, and 16

**CARRIAGE:**

Reinforced, bridge type carriage operates freely on a ball bearing race. Number of courses are variable to the maximum width of the needle bed. Cams are automatically controlled with three positions; knit, tuck, and welt. Two position stitch tension with automatic selection at both positions.

**YARN CARRIERS:**

Six independent and automatically controlled yarn carriers operating on three special coupled rails.

**PIECE COUNTER:**

Four digit piece counter with machine stopmotion.

**TAKE DOWN:**

Large diameter rollers with easily changed, wear resistant rubber sleeves. Adjustable pressure rollers are easily removed with one hand.

**PATTERN PROGRAMMING:**

Patterns are easily prepared directly on the machine using the operator interface computer.

**MOTOR:**

Three phase, 1/2 hp, 220 v, 60 hz power supply. Inverter controlled drive system with 8 computer selectable speeds for each carriage course.

**SAFETY DEVICES:**

D.E.S.A.C. knot catcher (original electro-mechanical device to release carriage), emergency stop, and machine stopmotion.

Number of Needles	
Gauge	Needles
3	130
5	218
7	303
8	348
10	434
12	521
14	608
16	694

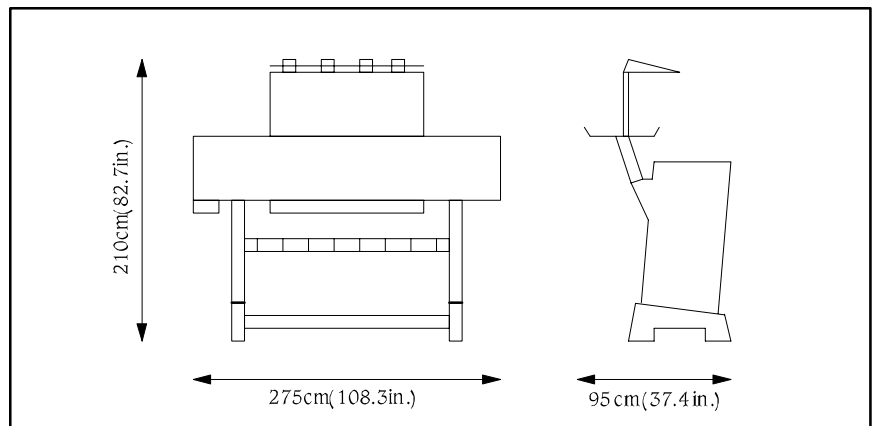

**Net Weight:** 457 kg (1,008 lbs.)      **Gross Weight:** 577 kg (1,272 lbs.)

**Shipping Dimensions:** 757 cm X 264 cm X 402 cm (298 in. X 104 in. X 158 in.)

All information in this brochure is given in good faith but without warranty.  
Machine characteristics are subject to change without notice.



A DIVISION OF MONARCH KNITTING MACHINERY CORPORATION

0903 © Vanguard Supreme

115 Secret Avenue • Monroe, NC 28110 U.S.A.  
Phone: (704) 291-3300 • Fax: (704) 283-7511 • Toll Free (800) 957-1582