

SEOMAR®

A-110 3PE

Flat Knitting Machine

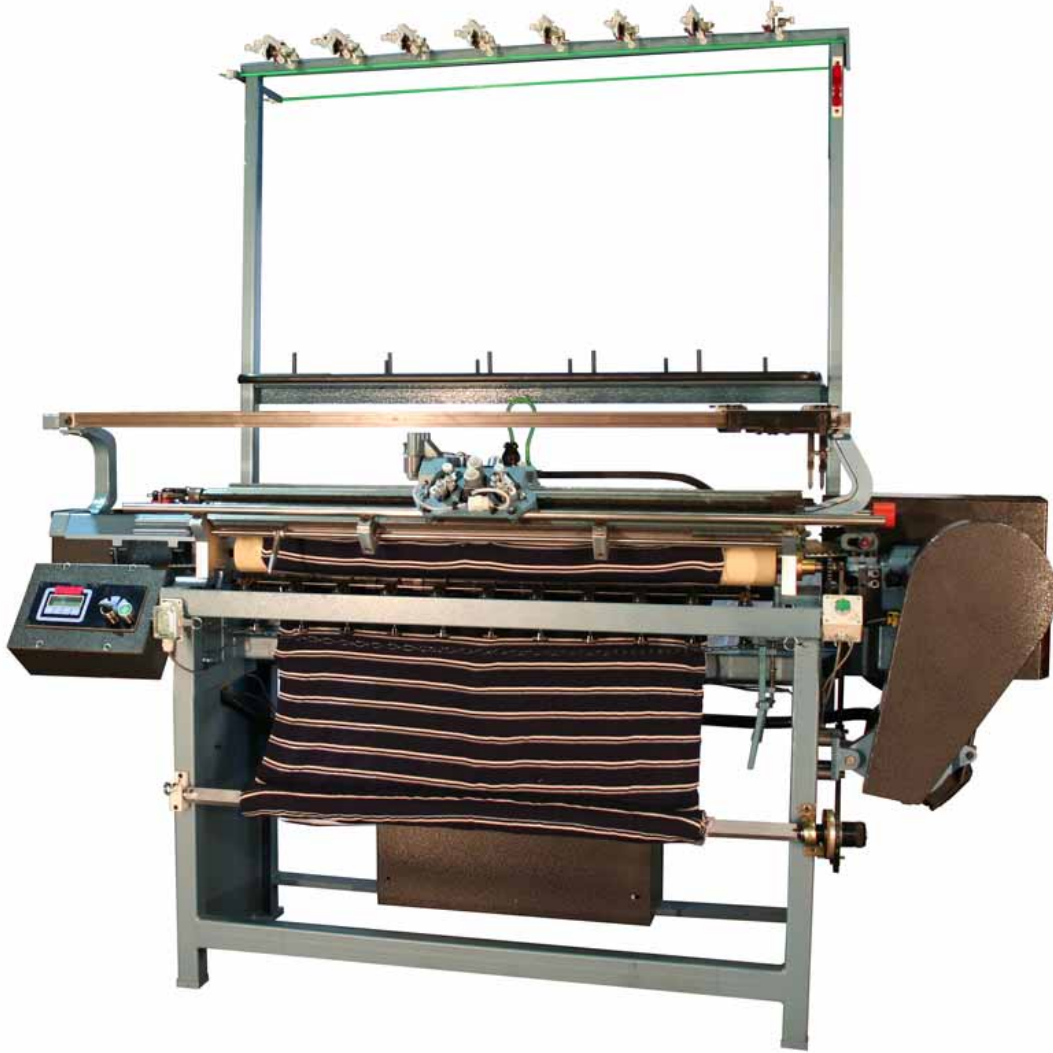

 **VANGUARD
SUPREME**

Assembled in U.S.A.

A-110 3PE

The Scomar A-110 3PE is the leader in fast trim machines. The A-110 3PE model is assembled according to Vanguard Supreme's new machine standards and updated with the latest computer control technology.

Technical Characteristics

NEEDLE BED:

110 cm wide.

GAUGES:

5, 7, 8, 10, 12, 14, and 16
(High and low butt needles)

CARRIAGE:

Low bridge type, reinforced running freely on ball-races. All cams are controlled by electromagnets. Automatic stitch settings with three positions each one. Stepless adjustable stroke from a minimum of 15 cm up to the maximum width of the needle bed.

YARN CARRIERS:

Four independent and automatically controlled yarn carriers operating on special coupled bars.

PIECE COUNTER:

Four digit piece counter integrated in the computer with machine stopmotion.

TAKE DOWN:

Large diameter roll, spring rollers, and easily changed wear resistant rubber sleeves.

PATTERN PROGRAMMING:

Patterns are easily prepared directly on the machine using the operator interface computer.

MOTOR:

Three phase, 1/2 hp, 220 v, 60 hz power supply. Inverter controlled drive system with 8 computer selectable speeds for each carriage course.

RACKING:

Automatic racking over 1, 2, or 3 needles and 1/2 fixed position. The machine can also be setup to meet specific needs.

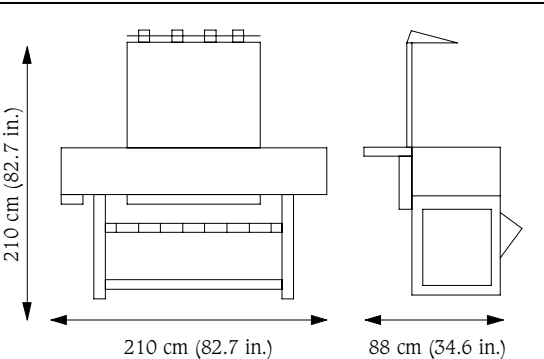
Number of Needles			Speed		
Gauge	Needles		Minimum: 40 courses/min. Maximum: 126 courses/min.		
5	218		Hourly Production	12 gg	7 gg
7	303		T-shirt Collars	60	120
8	348		T-Shirt Cuffs	120	240
10	434		Bodies and Sleeves	12	24
12	521		Pockets	150	250
14	608		Round Collars	60	120
16	694				

Net Weight: 385 kg (962 lbs.)

All information in this brochure is given in good faith but without warranty.
Machine characteristics are subject to change without notice.



A DIVISION OF MONARCH KNITTING MACHINERY CORPORATION

0806 © Vanguard Supreme

115 Secrest Avenue • Monroe, NC 28110 U.S.A.
Phone: (704) 291-3300 • Fax: (704) 283-7511 • Toll Free (800) 957-1582